

**Need Help?**  
**1-888-443-8889**



# VAULT

## MOBILE SERVICE CART SECURITY PANELING

### CART4426-VS

#### Magnum Vault Mobile Service Cart Security Paneling (for 4426 Series Service Carts\*)

**\*Also compatible with Rubbermaid Cart 4520-88.**

Rubbermaid is a trademark of Newell Brands. Use of the trademark does not imply a  
ffiliation with or endorsement.

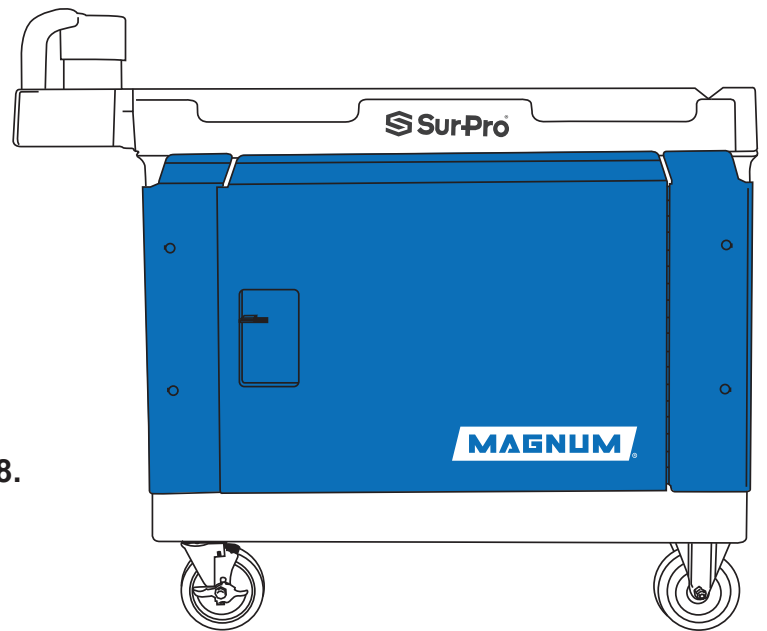

## INSTALLATION INSTRUCTIONS

**PLEASE READ INSTRUCTIONS AND WARNINGS BEFORE USE.**



Magnum Tool Corp., Inc. offers a one-year limited warranty on the Magnum Vault against manufacturing defects from the date of purchase. Excluded from all warranties are inbound freight or freight losses. At its own discretion, Magnum Tool Corp., Inc. will replace or repair the Vault and return it within a reasonable time. This warranty does not cover consequential damages, incidental damages, or damages to persons or property connected to the use of the Vault. Returns are not accepted without a valid Return Merchandise Authorization (RMA) Number obtained by Magnum Tool Corp., Inc. Please call 1-888-443-8889 to request an RMA Number prior to sending back the product.

**PACKAGING CONTENTS**

**Panel A** x1

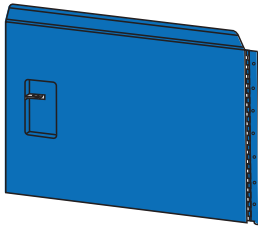

**Brace** x1



**Panel B** x1

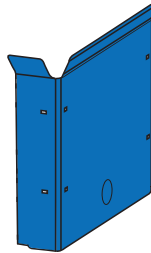

**Panel C** x1

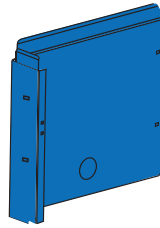

**Panel D** x1

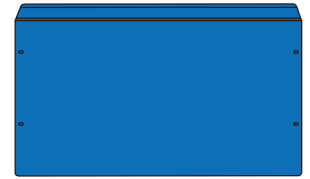

**Plastic Insert**  
x16



**10mm Carriage Bolt**  
x16

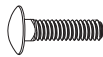

**10mm Flange Nuts**  
x16



**8mm Hex Bolts**  
x7



**Flat Washers**  
x7



**Split Washers**  
x7



**8mm Flange Nuts**  
x7



**2-Piece Plastic Grommets for Electrical Pass-through** x2



**8mm/10mm Wrench** x2

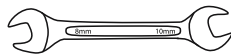

**Ensure that all parts are in the packaging.**

*Helpful Tip:* Using your own supplied 8mm/10mm deep sockets with Nut Driver would be ideal for installing nuts and bolts, but a Wrench is included.

**ASSEMBLY INSTRUCTIONS**

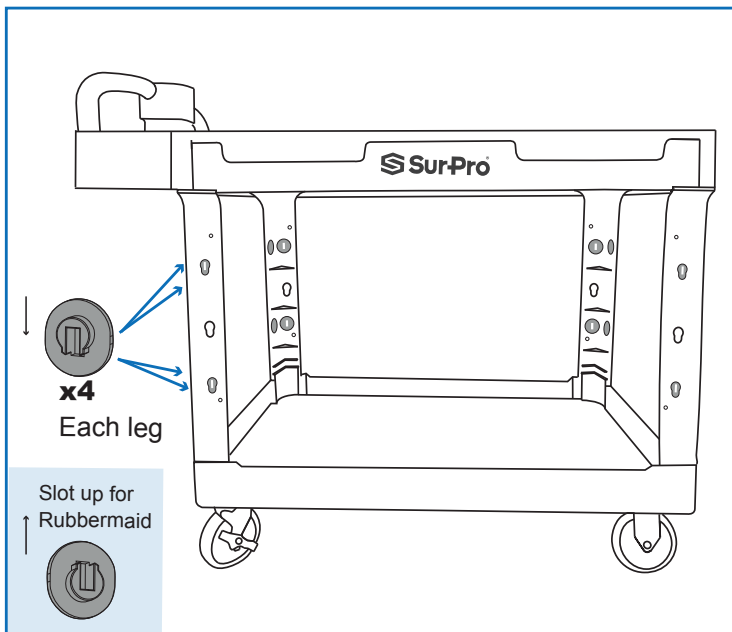

**1**

Place all 16 **Plastic Inserts (K)** into the back sides of all Service Cart legs - use 4 Plastic Inserts per leg. Note the orientation of the slot - position down for SurPro & Magnum Carts, and up for Rubbermaid Carts.

*Helpful Tip:* Use adhesive tape on the top and bottom of the Plastic Insert, while leaving the slot uncovered for the bolt to pass through. This will hold the Plastic Inserts in place while you complete further instructions.

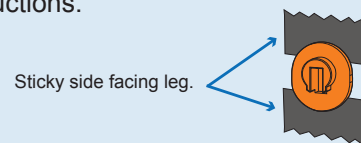

- 2** Lay the Service Cart flat on its side, logo side down. With the Plastic Inserts taped in place, attach **Panel D** to Service Cart with **10mm Carriage Bolts** and **10mm Flange Nuts**. Inserts bolts through the front of Panel D and secure nuts on backside of service cart leg(s).

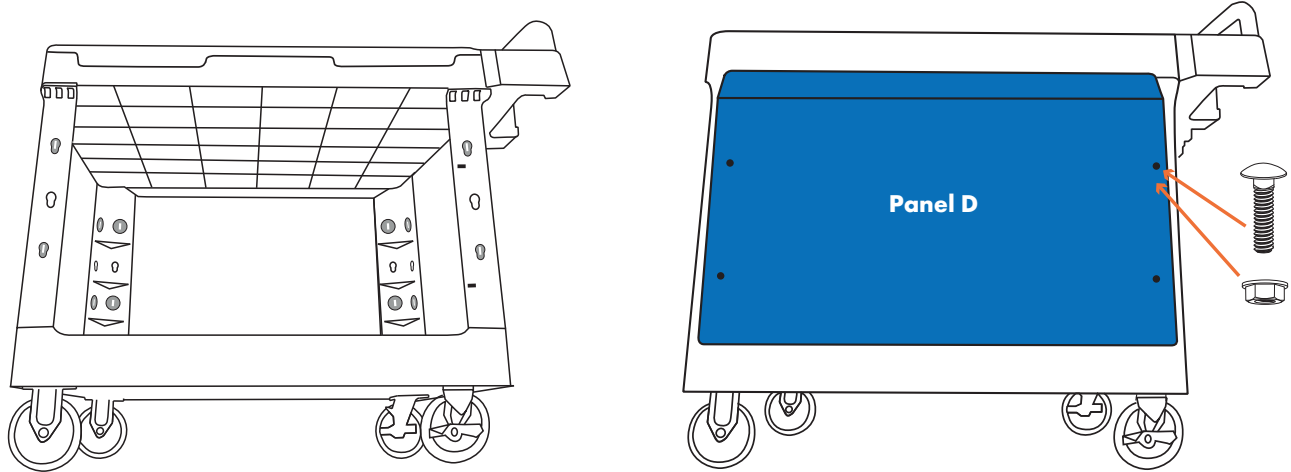

- 3** Stand the Cart on its casters. Lock the casters. Install **Panel C**. Secure with **10mm Carriage Bolts** and **10mm Flange Nuts**.

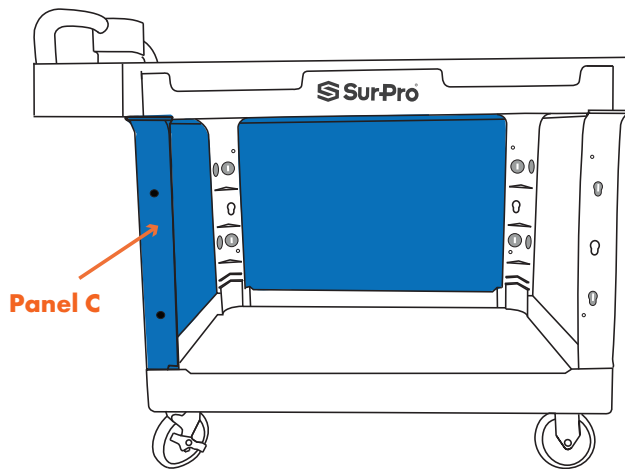

- 4** Install **Panel B**. Secure with **10mm Carriage Bolts** and **10mm Flange Nuts**.

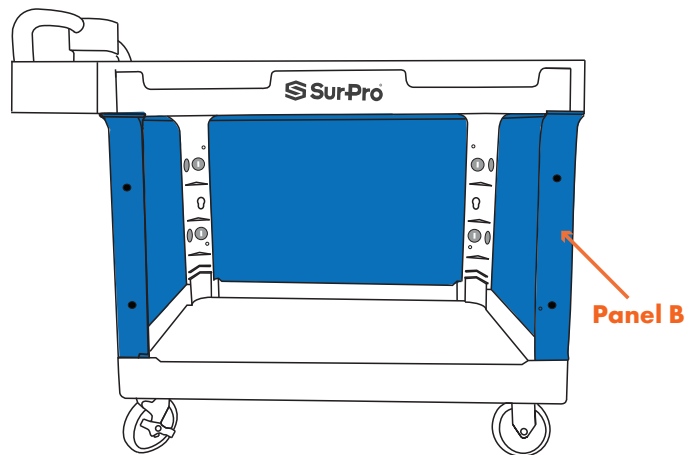

- 5** Attach **Panel A** to **Panel B** using four **8mm Hex Bolts** with **Flat Washers** and **8mm Flange Nuts** with **Split Washers** (Every other hole from the top as illustrated below). Make sure all seven holes are aligned.

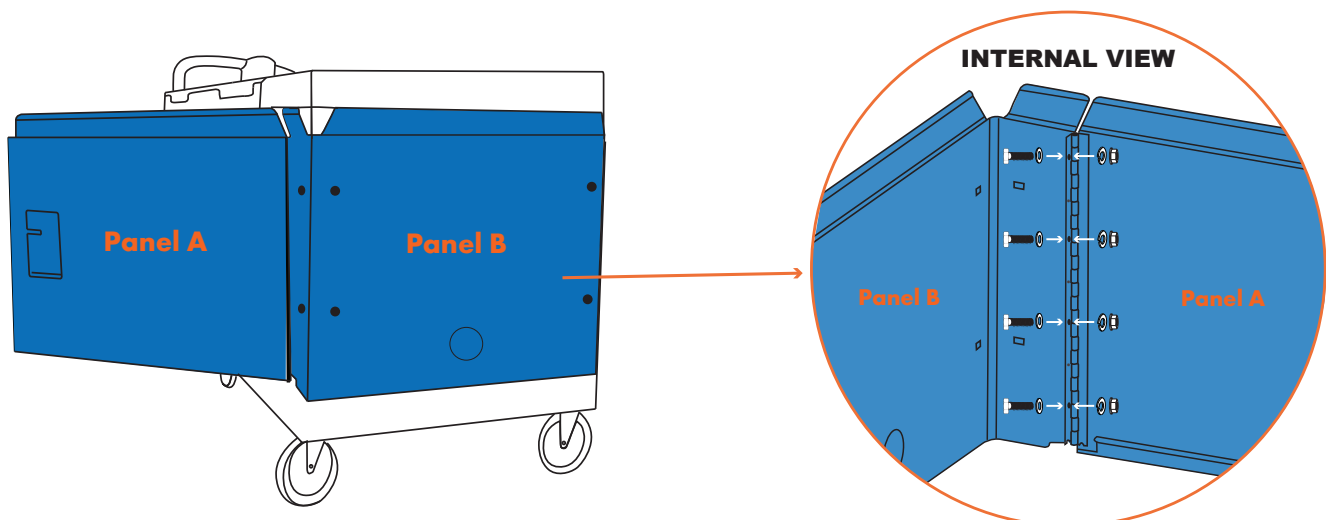

**6** Attach the **Brace** to the hinge as illustrated below and secure with **8mm Hex Bolts** with **Flat Washers** and **8mm Flange Nuts** with **Split Washers**

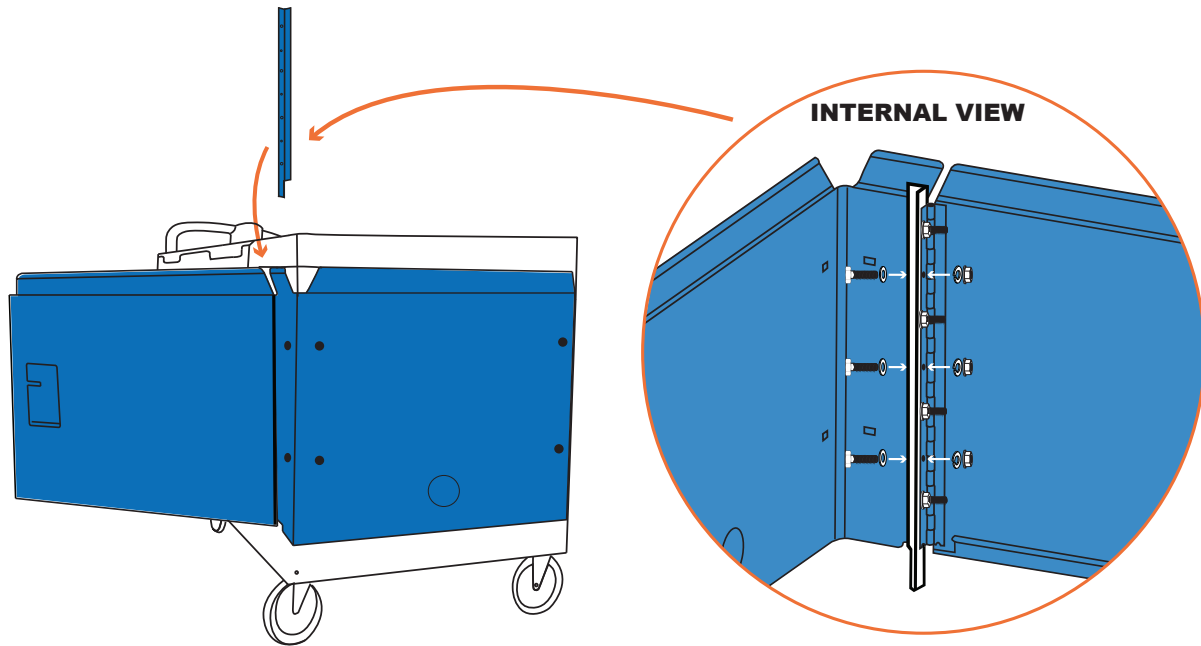

**7** If using optional knockout **Electrical Pass-through**, make sure to remove plate(s) first, then securely install the **2-Piece Plastic Grommets** onto the hole. One piece from inside and the other piece from outside - snapping together as illustrated below.

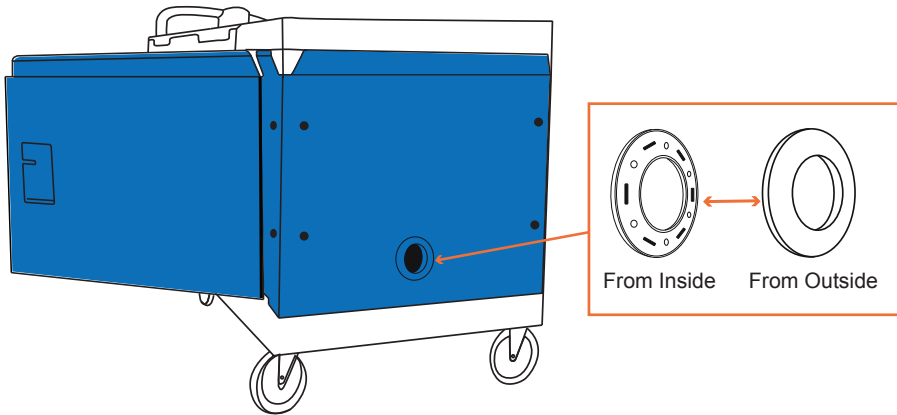

**⚠ WARNING**

Read, understand and follow all instructions and safety rules before use. Failure to do so could result in injury.

**⚠ CAUTION**

Never store flammables or any hazardous materials inside the Vault. Vault door should be secured when not in use, including transporting.

**NOTICE**

Magnum Tool Corp., Inc. is not responsible for any incidences or injuries to persons or property resulting from any unintended use of this product.



**Magnum Tool Corp, Inc.**  
**5600 Bonhomme Rd Suite B**  
**Houston, TX 77036**  
**+1 (888) 443-8889**