

MAGNUM[®]

DUC100-F

1 Cu. Yd. Covered Capacity Dump Cart with Forklift Ready Frame (Injection Molded)

1250 LB LOAD CAPACITY

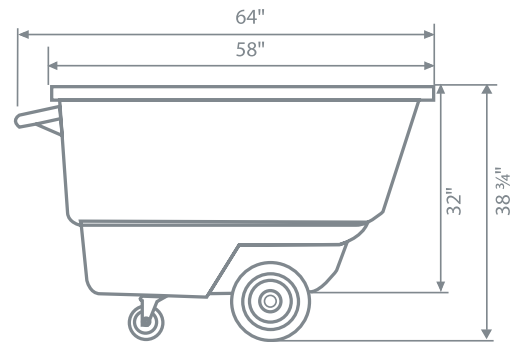
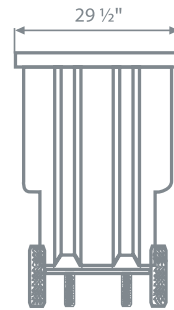

Max Load Capacity	1250 LB
Wheel Type	12" Heavy-Duty
Caster Type	5" Heavy-Duty
Item Weight	103 LB
Pallet Count	7 PC

- Dumping can be performed by a single user
- Smooth surface is easy to clean and resists corrosion
- Fits through standard doorways and elevators
- Save freight and space by stacking more on a pallet
- Construction grade wheels and casters

MAGNUM[®]

1-888-443-8889
MAGNUM-TOOL.COM
HOUSTON, TX

Please scan the QR
code to see the rest
of our dump cart line

